

OWNERS INFORMATION AND INSTRUCTIONS FOR MODEL PJM-WFC-50 1/2 HP

For safe operation, please read this information carefully before installation.
Save this information for future reference.

★ WARNING ★ Risk of Electrical Shock

- Always unplug sump pump from its power source before handling, in order to reduce risk of electrical shock.
- This pump is supplied with a grounding conductor and grounding type attachment plug. To reduce risk of electrical shock, be certain that grounding conductor is connected only to a properly grounded, grounding type receptacle.
- This pump has **not** been investigated for use in swimming pool areas. **THIS PUMP IS DESIGNED FOR DOMESTIC RESIDENTIAL USE AND SIMILAR APPLICATIONS.**
- Do not plug this product in while you are standing in water or on a wet surface.
- Caution — Install pump with motor and all electrical components above the top grade level of the sump cover. **THIS SUMP PUMP IS NOT SUBMERSIBLE.**
- Caution — Installation and testing of electrical circuits should be performed by a qualified electrician.
- Do not lift this pump by the electrical cord.

**WARRANTY IS VOID IF
CORD IS CUT, DAMAGED
OR IF THE GROUNDING
PLUG HAS BEEN
REMOVED.**

INSTALLATION INSTRUCTIONS

1. Unplug existing pump from its power supply and then carefully lift pump from sump pit.
2. Thoroughly clean sump pit to remove all debris and litter including any gravel and/or mud.
3. Check new pump over to see that it has not been damaged in shipment. Make sure float and rod move freely up and down for free switch operation.
4. Install threaded discharge pipe. Hand tighten discharge pipe into the 1/4" NPT threaded pipe discharge.
5. Tape electrical cord to the discharge pipe to keep it free and clear of the float mechanism and high and dry of the sump pit itself.
6. Lower pump into center of sump pit and let it rest on a patio block, brick or flat surface for secure installation.
7. Connect discharge pipes together with check valve or rubber union. (A check valve is recommended to prevent water from draining back into the sump pit.)
8. Carefully add several gallons of water to the sump pit to test pump and to make sure float and rod mechanism travels freely and activates the pump switch.
9. A sump pit cover should be placed over the sump pit after the sump pump has been installed. This will help prevent foreign objects from falling into the basin and to prevent injury.

The homeowner is responsible for keeping this sump pump clean and the sump pump pit free of mud, lint and other debris.



JIM MURRAY, INC.

Your Partners in Pumping Since 1958
www.jimmurrayinc.com

N116 W18455 Morse Drive
Germanstown, WI 53022-2487
Phone: (262) 253-1353

RECOMMENDED INSTALLATION

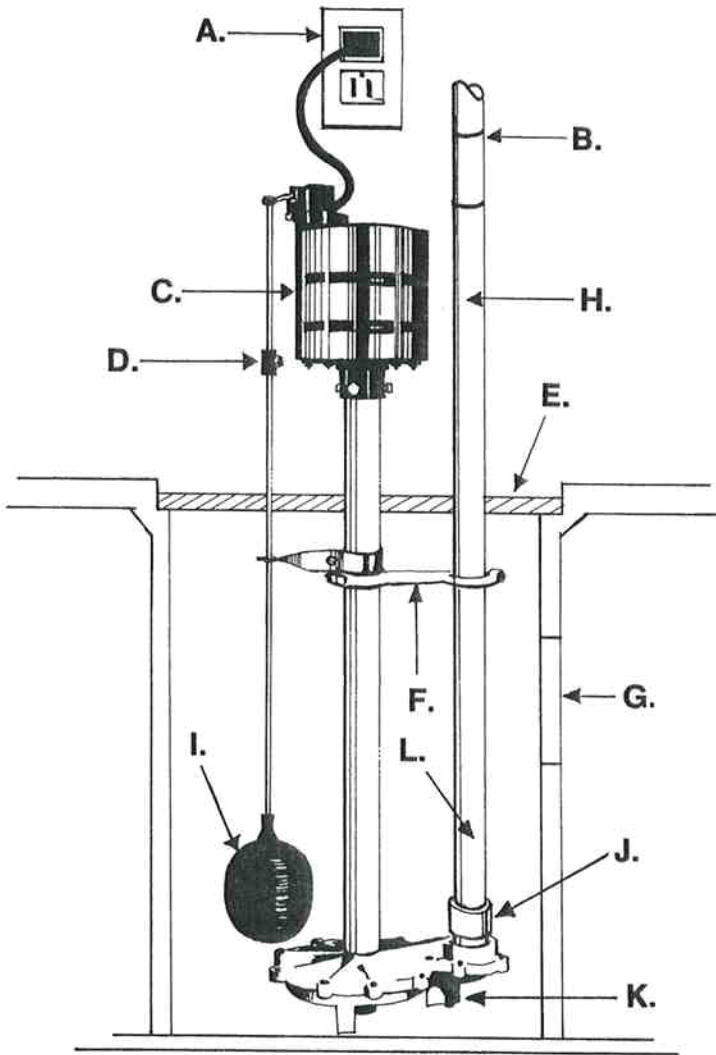

- A. Properly grounded 3-prong electrical fixture with appropriate fuses or circuit breaker on a separate branch circuit is recommended.
- B. Check valve or rubber union.
- C. Motor above ground surface.
- D. Adjustable stop (float mechanism).
- E. Cover installed to keep debris out of sump pit.
- F. Discharge pipe guide.
- G. Drain tile.
- H. Discharge pipe.
- I. Float must travel free up and down.
- J. 1/4" NPT female discharge.
- K. Flat resting surface block. Keep it free and clear of all debris.
- L. When using a check valve, drill 3/16" hole in discharge pipe below level of drain tile.

GENERAL INFORMATION

- Keep Sump and Pump free of sediment and debris. If needed, remove pump and clean sediment and debris from pump and sump pit.
- The adjustable stop on your float mechanism is pre-set at 9". You may adjust it to a setting which best suits your needs.
- It is recommended that you operate your pump monthly. Do this by carefully adding enough water to sump pit to activate the switch allowing the sump pump to run its normal cycle.

LIMITED WARRANTY

All items in this product are guaranteed against defects in workmanship or materials for a period of one year from date of installation or purchase. Proof of purchase required.

Liability in all events is limited under the aforesaid guarantee to replacing or repairing any part or parts which are defective in materials or workmanship and are returned to us shipping costs prepaid.

Jim Murray, Inc. shall not be liable for any special, indirect, incidental or consequential damages.

Warranty is void if cord is cut or damaged or if grounding plug has been removed.

No Warranty, expressed or implied, other than the aforesaid guarantee is made or authorized. — **Jim Murray, Inc.**

This warranty gives you specific legal rights, and you may also have other rights which may vary from state to state.

PARTS LIST FOR MODEL PJM-WFC-50

PART NO.	DESCRIPTION
CJM-GERB-50	GE-Regal-Beloit 1/2 HP Motor with switch and cord
KJM-JM-50	Upright Base Assembly Kit with Guide Arm
KJM-FK-001	Float Kit (Complete Float Assembly)
KJM-AH-001	Upright Switch Replacement Kit
CJM-CP-001	Shaft Coupling
CJM-SFT-04	Drive Shaft - Stainless Steel
CJM-IMP-38	Upright Impeller
CJM-BRS-01	Bearing
CJM-PT-01	Pump Column
CJM-SCW-10	Stainless Steel Drive Pin
CJM-SET-01	Pump Volute - Top, Bottom & Impeller
CJM-SCW-06	Stainless Steel Screws for Pump Volute (13 required)
CJM-GA-01	Guide Arm
CJM-ST-01	Rod Stop
CJM-SO-01	Stand Off
CJM-FB-01	Float Ball
CJM-FR-02	Float Rod



JIM MURRAY, INC.

Your Partners in Pumping Since 1958
www.jimmurrayinc.com

N116 W18455 Morse Drive
Germantown, WI 53022-2487
Phone: (262) 253-1353