

PIPE SEALING COUPLING - 2"

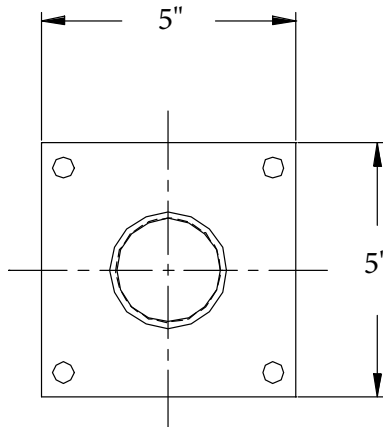
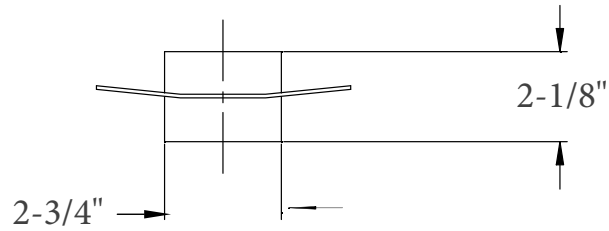

2" FPT PIPE COUPLING
STAINLESS STEEL

Model C200S

* Stainless Steel Hardware & 3M Sealant Provided

INSTALLATION INSTRUCTIONS

1. LOCATE PIPE OR COUPLING CENTER.
2. CUT HOLE TO THE OUTSIDE DIAMETER OF THE COUPLING.
3. APPLY GASKET TO COUPLING OR BASIN.
4. PLACE COUPLING AND DRILL HOLES FOR BOLTS.
5. INSERT BOLTS, WASHERS, NUTS AND TIGHTEN.

INDUSTRIES
TOPP
INCORPORATED

PIPE COUPLINGS

Reference:

Highway 25 North P.O. Box 420
Rochester, IN 46975
Phone: 800/354-4534 Fax: 874/223-6106

Scale: None

Drawn By: RM

App'd By:

Date:

Supersedes Prints
Prior To:

This print is and contains confidential proprietary information owned exclusively by TOPP INDUSTRIES, INC. It is furnished on a strictly confidential basis. This restriction includes, but is not limited to the condition that this print will not only be used as a record or to identify or inspect parts or for other information purposes and will not be used to manufacture or procure the manufacture of the items shown in this print by any other source than TOPP INDUSTRIES, INC.

09-07-13